

Baseline assessment

Name: _____ Form: _____

Physics group: _____

GCSE Physics/Science grade: _____

Date: _____

Targets for improvement

-
-
-
-
-
-
-

Question	Marks
1	/5
2	/6
3	/10
4	/8
Motion total	/29
1	/6
2	/6
3	/12
Electricity total	/24
Grand Total	/53
%	
Grade	
Target grade	
<input type="checkbox"/>	OT
<input type="checkbox"/>	BT
<input type="checkbox"/>	AT

Motion

1 A car is travelling along a level road.



- a The car travels at constant velocity. It covers 250 m in 40 s. Calculate the average velocity during this time.

(2 marks)

- b The car now accelerates in a straight line.
Its average acceleration is 12 m/s^2 .
Calculate the increase in velocity of the car in 4.0 s.

(3 marks)

2 The graph shows a velocity-time graph for a cyclist over a time of 60 s.

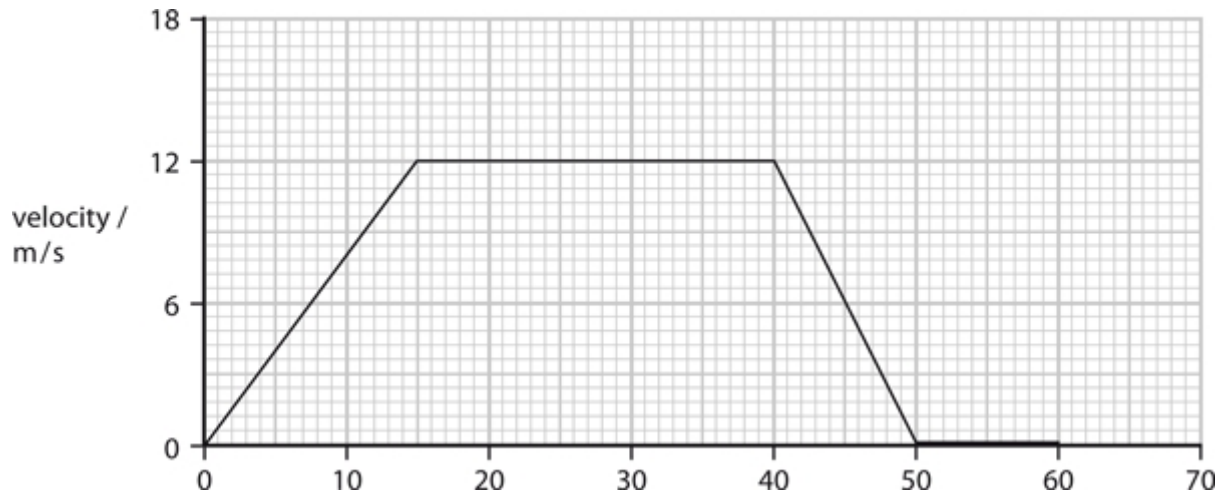

a i When is the cyclist travelling with greatest velocity?
Place a cross (☒) in the box next to your answer.

- A for the first 15 seconds
- B between 15 and 40 seconds
- C between 40 and 50 seconds
- D for the last 10 seconds

(1 mark)

ii Calculate how long the cyclist is stationary for in seconds.

(1 mark)

iii Calculate how far the cyclist travels in metres during the first 40 seconds.

(1 mark)

- b A different cyclist accelerates for 8 s. During this time they accelerate from 3 m/s to 14.2 m/s.
Calculate the acceleration during this time.

(3 marks)

- 3 A water tank drips water.

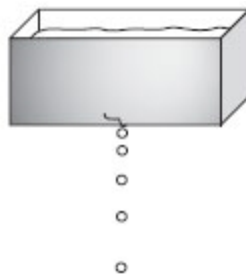

- a Scientists could use four quantities to describe the movement of the water drops. Three of these quantities are vectors. The other quantity is a scalar.

acceleration	force	mass	velocity
--------------	-------	------	----------

- i Complete the sentence by putting a cross (☒) in the box next to your answer.

The scalar quantity is...

- A acceleration
- B force
- C mass
- D velocity

(1 mark)

- ii State any vector quantity **not** listed above.

(1 mark)

- iii** Complete the following sentence using one of the quantities from the word box above.

In a vacuum, all bodies falling towards the Earth's surface have the same

_____.

(1 mark)

- b** The mass of one water drop is 0.00008 kg.
Calculate its weight in Newtons.
(Gravitational field strength is 10 N/kg)

(2 marks)

- c** The water drop falls to the ground, 13 m below, in 1.7 s.
Calculate the average speed in m/s of the drop while it is falling.

(2 marks)

- d** Assuming the droplet starts at rest calculate the velocity just before it hits the ground. Ignore air resistance.
($g = 10\text{m/s}^2$)

(3 marks)

4 The graph shows how the velocity of a small car changes with time.

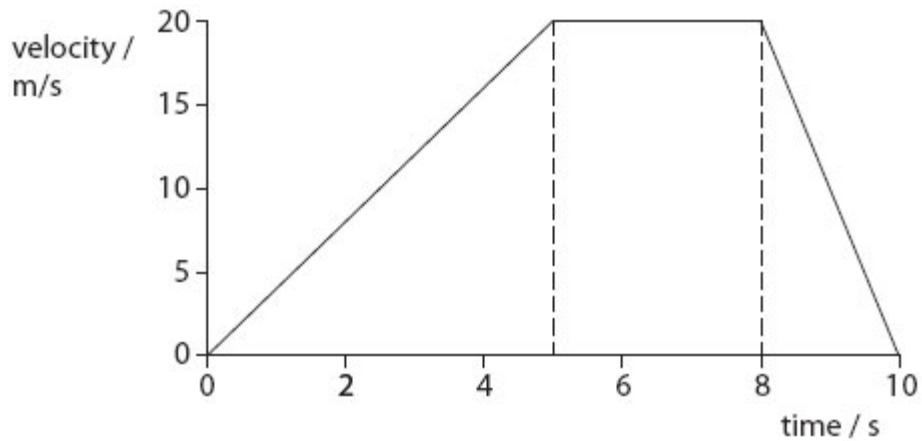

a Use the graph to estimate the velocity of the car at three seconds.

(1 mark)

b Calculate the acceleration in m/s^2 of the car when it is speeding up.

(2 marks)

c Explain why the units of acceleration are m/s^2 .

(2 marks)

d Show that the car travels further at a constant velocity than it does when it is slowing down.

(3 marks)

Electricity

- 1 Some students investigate the electrical resistance of different components using this circuit.

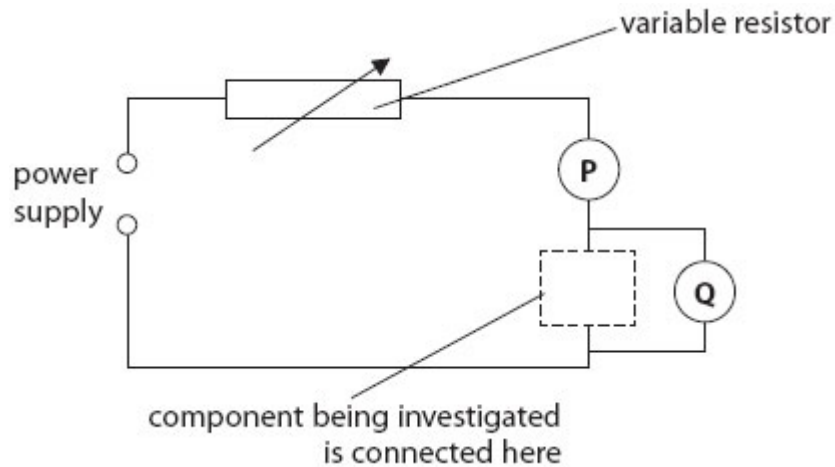

- a Which row of the table is correct for both meters P and Q?
Place a cross (☒) in the box next to your answer.

	meter P is	meter Q is
A	<input checked="" type="checkbox"/> an ammeter	an ammeter
B	<input checked="" type="checkbox"/> an ammeter	a voltmeter
C	<input checked="" type="checkbox"/> a voltmeter	a voltmeter
D	<input checked="" type="checkbox"/> a voltmeter	an ammeter

(1 mark)

- b One of the components being investigated is a 12 ohm resistor.
When it is in the circuit, the ammeter reading is 0.50 A.
Calculate the voltmeter reading.

(2 marks)

- c The students reduce the resistance of the variable resistor.
State what happens to the readings on each of the meters P and Q. Explain what happens to P.

(2 marks)

- d The students then reduce the voltage of the power supply.
State what happens to the current in the circuit.

(1 mark)

- 2 a The diagram shows an electric circuit with two resistors, R and S.

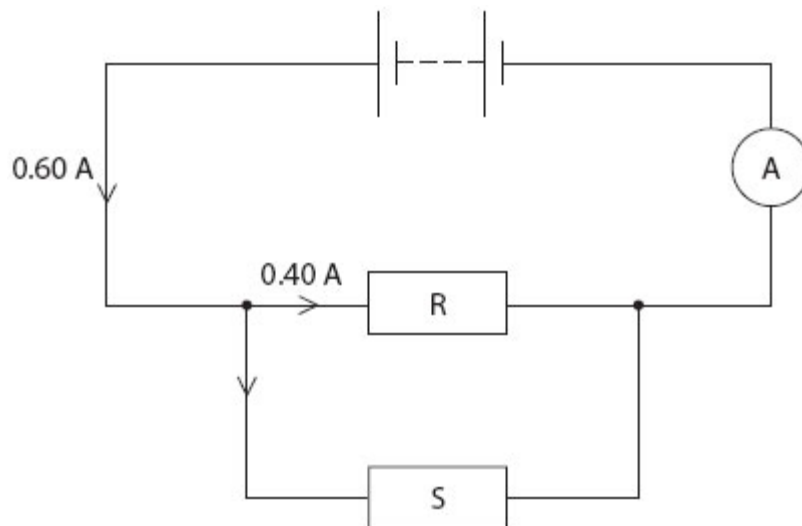

- i R has a resistance of 11 ohms.
Calculate the potential difference across R.

(2 marks)

ii Use information from the diagram to calculate the current in S.

(1 mark)

iii Calculate the resistance of S.

(2 marks)

b Complete the sentence by putting a cross (☒) in the box next to your answer.

A student wants to measure the battery voltage with a voltmeter.
The voltmeter should be placed...

- A in series with the battery
- B in parallel with the battery
- C in parallel with the ammeter
- D in series with either resistor R or S

(1 mark)

3 The diagram shows an electric circuit with three resistors, R_1 , R_2 and R_3 .

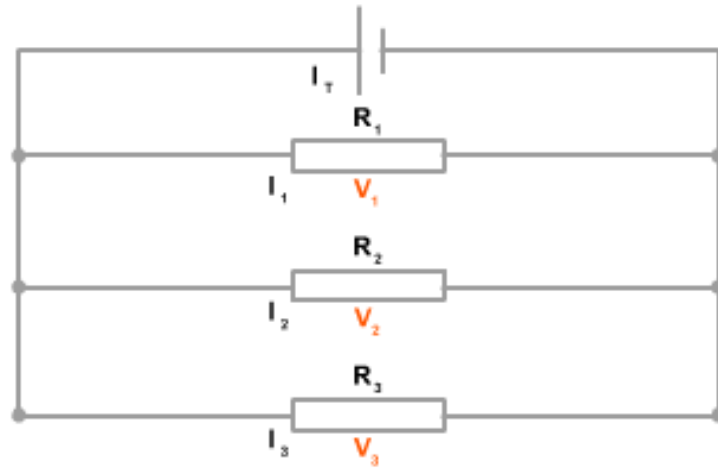

- a i R_1 has a resistance of 5 ohms. The current flowing in it is 2A.
Calculate the potential difference across R_1 .

(2 marks)

- ii State the voltage provided by the battery

(1 mark)

- b i** The resistance of R_2 is 10 ohms and R_3 is 4 ohms. Calculate the combined resistance of R_1 , R_2 and R_3 in this arrangement.

(4 marks)

- ii** Calculate the current being produced by the battery.

(2 marks)

- c** Calculate the current flowing in:

i R_2

ii R_3

(3 marks for **i** and **ii** combined)

-End of assessment-